

BASIC SUPPORT SOFTWARE IN THE AREA OF ELECTRICAL ENGINEERING FOR LATIN AMERICA

João R. Cogo

Escola Federal de Engenharia de Itajubá
Av. BPS, 1303 - 37500-000 Itajubá/MG - Brazil
Phone: (035)622-1613 - Fax: (035)622-2337

Hermann W. Dommel

The University of British Columbia
2356 Main Mall, Vancouver, B.C - Canadá
Phone: (604)822-2793 - Fax: (604)822-5949

Artigo apresentado no XI Congresso Chileno de Ingeniería Eléctrica (Electro'95)
Universidad de Magallanes, Punta Arenas/Chile, 13 à 17 November, 1995

1. ABSTRACT

Many times, while contributing papers, preparing Mastership dissertations or Doctorate thesis, people within their working area need to develop electrical network simulation programs, which are not part of their specific interest. So, this work purposes a joint action among the people interested in simulating electromagnetic transients so as to supply basic programs and case studies to lessen the computational effort in the area of electrical engineering.

2. OVERVIEW

Presently, government and companies have an even greater interest in improving the products quality, so as to make them more competitive both in the national and foreign market.

This quality improvement, at an accessible cost, must be obtained through technology developed within the country. That means that all the institutions involved with researches, system behaviour studies, projects, etc., should be included in this context as well.

It is to be noted that the production and consumption of electrical power is one of the major interests of government-companies. So, researches and studies (at university and company level) in the area of generation, transmission, distribution and mainly consumption of electrical power, waste too much time in working out basic stages, to finally attack the main objective of the general issue, i.e., analysis of a specific problem, in a later time.

As an example, let the following cases be assumed:

I. Suppose an institution wants to conduct a study so as to minimize the consumption of industrial electrical power.

As the surveys show, over half of the consumption of industrial electrical power is due to cage-type three-phase induction motors. Any research intending to get palpable results in terms of power saving should dedicate, even that partially, to the motor study. For such, a motor model must be developed, which besides being reliable, can be obtained through data available from manufacturers catalogues. The researcher will be taken a long time for the model development. If the model is available already, the main problem is solved faster.

II. If one is interested in developing a specific speed control of a system with DC machine, one will certainly need to model the electrical grid, the converter bridge and the DC machine itself, but the main goal is just the development of the control grid.

Should the user have an interface routine available to him, through which he could implement only the model of his interest, much time could be saved.

In the previous example, in case there was already a program with the models of the electrical grid, of the DC machine and of the converter bridge, it would suffice to the user to implant his specific control routine and to analyse the electrical system as a whole.

3. PLANNING

Creation of a basic working group of teaching and research institutions aiming to discuss and better suit the existing models to the ones to be developed. Within this working line, as a starting point, the Electromagnetic Transients Program - Student Version, developed by Microtran Power System Analysis Corporation is suggested.

4. RESULTS TO BE OBTAINED

The availability of a Library of Basic Programs to the researchers will certainly result in an enormous saving of time for reaching specific results in the area of electrical engineering.

The program proposed initially will provide the basic subsidies for development of bigger programs with the aim of researches in the area of generation, transmission, distribution and consumption of electrical power.

This basic library is suitable both for studies and for development of new technologies.

Such a project is justified by the fact that it spurs a process of integration of softwares either developed or under development by several research institutions, guaranteeing efforts to be done to direct and conjugate such researches.

5. METHODOLOGY

Each one of the programs proposed will be developed and implemented for microcomputers IBM PC compatible in a language adequate to each case, with user manuals containing applicative examples, preferably on line.

The programs will be supplied in diskettes containing the executable program and the respective manual with applicative examples. The individual with an interest should send the diskettes to the development centers (universities, research centers) without involving institutions by creating an informal group in which the

persons with common interests and specific area are listed.

6. THE MICROTRAN PROGRAM

The MicroTran® program, in its present MT32 version, is an electromagnetic transients analysis program designed for simulation of power systems with up to 2000 bars and applications of power electronics, developed by H.W. Dommel, J.R. Marti and L. Marti for personal computers based on DOS platform from a previous version for mainframes. For over 20 years, MicroTran and its predecessor (also known as EMTP UBC version) has been used as a primary tool of analysis and development for research of electromagnetic transients phenomena at the “The University of British Columbia”, and by consulting engineers and utilities around the world. MicroTran has been used in more than 25 universities worldwide, and its users base spans 20 countries and 4 continents, being probably the fastest transient analysis program available to a PC platform.

The program capabilities, among others, include the modelling of lumped R, L, C elements, multiphase pi circuits, n-windings ideal or non-ideal transformers (single- or three-phase), distributed parameters transmission lines transposed and non-transposed with constant parameters or frequency-dependent parameters, non-linear resistances and inductances and arresters, switches with any number of opening/closing sequences, diodes, thyristors, transistors, GTO's, IGBT's, synchronous machines, voltage and current sources pre-defined or point-to-point specified as time functions. They can be also calculated within the user-supplied SOURCE subroutine, etc.

The users can create and test their own linear or non-linear models by using the routine CONNEC available. The procedure is very simple: the user compiles his version of CONNEC (written in Fortran 77 standard) and re-connects it with the rest of the program. There is a sample version

of CONNEC and detailed interface information for possible developments.

The input data file can be created and edited with a standard ASCII editor or with the Microtran dedicated pre-processor mtData.

The output processing and plotting program mtPlot is a fast and easy to use plotting program, with features including automatic scaling in linear and/or logarithmic scales, graphical cursor showing continuously the x and y coordinates values, graphical editor that permits the input of text and other primitive graphical elements directly upon the plotted image, etc.

The mtLine is a full-featured overhead parameters program, and fdData provides support for frequency-dependent line models.

Some of the capabilities of the mtLine include the calculation of series impedance matrices and shunt capacitances of overhead transmission lines with an arbitrary arrangement of up to 100 phase conductors and/or ground wires, output in phase or modal quantities or with symmetrical components, multiphase pi circuits, calculation of mutual impedances between power lines and communication circuits for interference studies, etc.

The MicroTran program capabilities allow for the user to implement his own electrical equipment models. One of these alternatives is the elaboration of control routines for the thyristors ignition angles, performed from the Alpha subroutine. Besides, it permits the access to the program output variables, making the changes that will serve as a basis for actuation of the converter bridge control system relatively easier.

7 - VERSION MT STUDENT

The student version of the MicroTran Package contains the same models as the production version. The main difference is that the data cases that can be run are smaller, but quite sufficient for classroom use. The screen dump program

GRAFPLUS is also not provided. To obtain hardcopy output, the DOS GRAPHICS command must be used (it does not have all the features GRAFPLUS has, but it is usable in a number of hardware configurations).

The limits imposed on the programs are as follow:

1. MicroTran: 18 nodes, 12 branches, 1 frequency dependent line.
2. fdData: 5 phases
3. mtline: 5 phases
4. mtplot: 3 curves/plot, 3 files/run
5. mtdata: 300 data lines.

In this version the CONNEC routine is not available.

The program performance can be verified by the simulation of the three cases below by using the version student.

Case 1 - Analysis of the converter bridge in Graetz formation

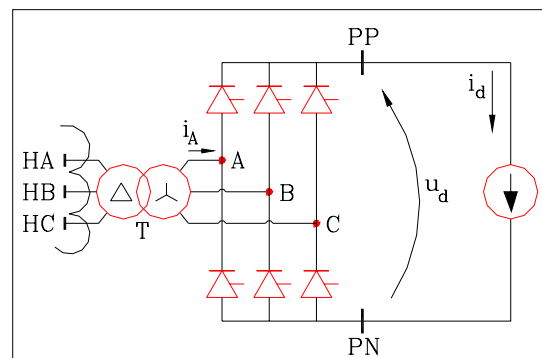

Figure 1. System under analysis.

where in figure 1:

T - transformer: 13.8/4.16[kV]; 5[MVA];
 $Z\% = 6.7\%$; $X/R = 8$. Connected in delta/star insulated

I_d - constant current load = 450[A]

The simulation results are in figure 5.

Case 2 - Energization of capacitor banks

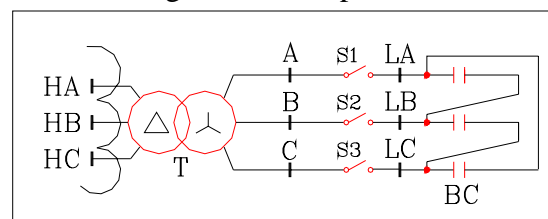

Figure 2. System under analysis

In figure 2:

T - transformer: 13.8/4.16[kV]; 5[MVA];
Z% = 6.7%; X/R = 8

BC - capacitor bank 1[MVAr]; 4.5[kV]

The simulation results are illustrated in figure 6 considering that the switches S1, S2 and S3 have the following operating form.

S1 - closes at 2.166[msec] and opens at 8.0[msec]

S2 - closes at 3.166[msec] and opens no more

S3 - closes at 4.66[msec] and opens no more

Case 3 - Line Parameters

For a 230[kV] typical line with the following configuration

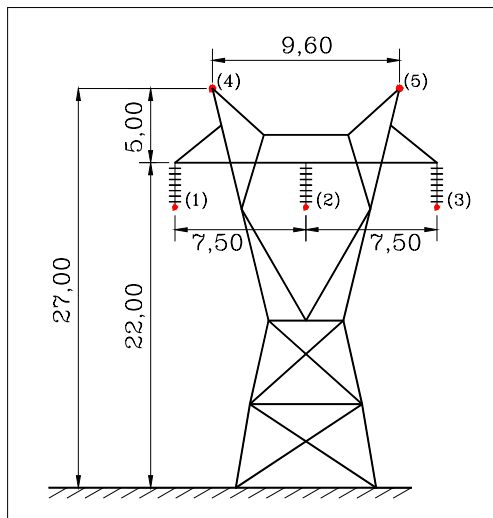

Figure 3. Tower under analysis so as to obtain the transmission line parameters.

The tower shown in figure 3, besides having the dimensions illustrated, has the following characteristic data:

Phase conductor diameter = 28.11[mm]

Phase conductor resistance = 0.08[Ω/km]

Skin effect of the phase conductor = 0.3159

Shielding conductor diameter = 9.14[mm]

Shielding conductor resistance = 4.189[Ω/km]

Shielding conductor skin effect = 0.500

Ground resistance = 10[Ω/km]

The simulation results obtained for the transmission line presented in figure 3 were, among others, the ones shown in the table below

In the table:

Z_0 - Surge impedance

V - Wave speed

R - Line resistance

XL - Line inductive reactance

XC - Capacitive susceptance

λ - Wave length

Sequence	Z_0 $\Omega \cdot 10^3$	V km/sec	R Ω/km	XL Ω/km	XC S/km	Attenuation DB/km	λ km
Zero	0.84356	187980.0	0.472260	1.64190	0.24009E-5	0.24554E-2	3133.00
Positive	0.39468	291510.0	0.081307	0.50554	0.32870E-5	0.89752E-3	4858.60

8. CONCLUSIONS

From the simulation results obtained in figure 5 it is realized the non-existence of numerical oscillation besides being possible to check the commutation effects on current and voltage signals. Although the results have been presented for a balanced system,

it is possible to represent an unbalanced one with differences in the trigger angles.

On the other hand, the simulation with the capacitor bank besides permitting to represent the switches with a difference in the energization and desenergization times, makes clearer the correct opening of switch S1 that, according to the simulation results,

is only opened after the current signal has gone through zero.

As far as we can see, a program with such a capability of representing the electrical network either in the area of electric power systems, or industrial systems, or applied electronics will contribute a lot to the quality and efficiency of both the engineering teaching and the development of academical works, permitting to create a case base that will surely contribute to the learning of everyone involved in this sector.

BIBLIOGRAPHICAL REFERENCES

MicroTran Electromagnetic Transients Analysis Program. Microtran Power System Analysis Corporation, Vancouver, B.C., Canada. Technical Report 1993.

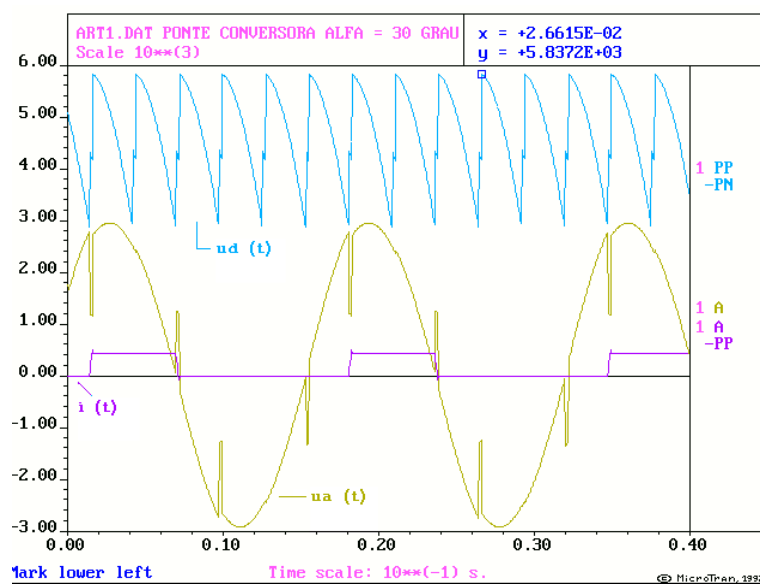

Figure 4. Waveshapes of the nodal voltage - of phase A - $u_a(t)$; voltage on the dc side - $u_d(t)$ and current in the diode - $i_d(t)$. $i_d(t)$ in the plotting has a scaling factor of 1.6.

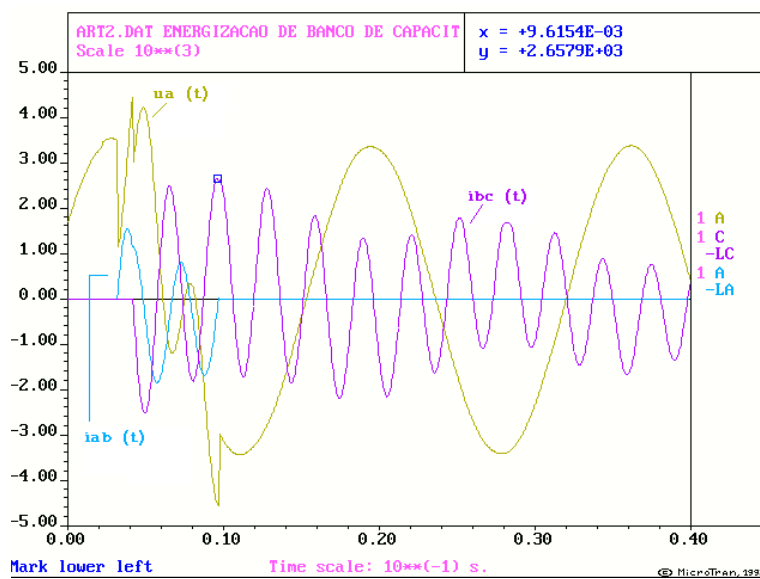

Figure 5. Waveshape of nodal voltage in phase A - $u_a(t)$ and current in the capacitor bank between phases LA-LB - $i_{ab}(t)$ and LB-LC - $i_{bc}(t)$.